



# THICKNESS MEASUREMENT

ENSURING QUALITY  
AND SAVING RESOURCES

# OPTIMAL PRODUCTION CONTROL



02/03

## RELIABLE THICKNESS MEASURING VALUES - THE BASIS TO REDUCE COSTS

Identify quality deviations at an early stage, take effective counter-measures and optimise the use of resources: These are only some challenges which we help you to overcome with our measuring technology systems. Whether you want to build up, remove or form material - the thickness of the resulting product is one of the most important quality features.

GreCon thickness measuring systems provide highly precise and reliable values of the material thickness and make them available to you for quality assurance and production optimisation.

These measurements can be taken either in the passage or stationary, at roll-type (endless) products or individual panel pieces.

Depending on the type of application and the job, roller or contact measuring probe heads and contactless laser measuring heads are used. Stable O-frame systems tailored to the specific installation situation make the use of the thickness measuring systems possible even under extremely difficult conditions.

The modular design with optimally matched components and the different available measuring elements facilitate a thickness measurement of different materials. Solid, loose and soft material properties are covered as well as transparent, colourful or single-colour surface and colour properties.



## PRODUCTION WITHOUT ALLOWANCES

04/05

### USE THE SAVINGS POTENTIALS

Besides the requirements of a uniform product quality, material savings and the corresponding cost controls have high priority. Material allowances for the following production and processing steps can be reduced diligently thanks to the continuous control of the thickness. Thus, it is for example possible to increase the material efficiency by reducing the grinding allowance - which means a reduction of the production costs.

The production capacity can be optimised in other processes in which the material thickness is influenced by the production speed. When looking at the product quality, quality costs can be cut by avoiding complaints and are comprehensible based on the recording function of the measuring system.

The use of a GreCon thickness measuring system quickly pays off.

### YOUR BENEFITS AT A GLANCE

- Increase of the material efficiency = reduction of the production costs
- Automatic calibration to compensate the environmental influences
- Continuous quality control and recording
- Feedback of the measured values to regulate the production
- Connection of scales to make a determination of the bulk density possible
- Accessibility for maintenance purposes also during production and calibration in an endless line by ct measuring frames
- Modular design - good extensibility and adaptation to changed demands and requirements

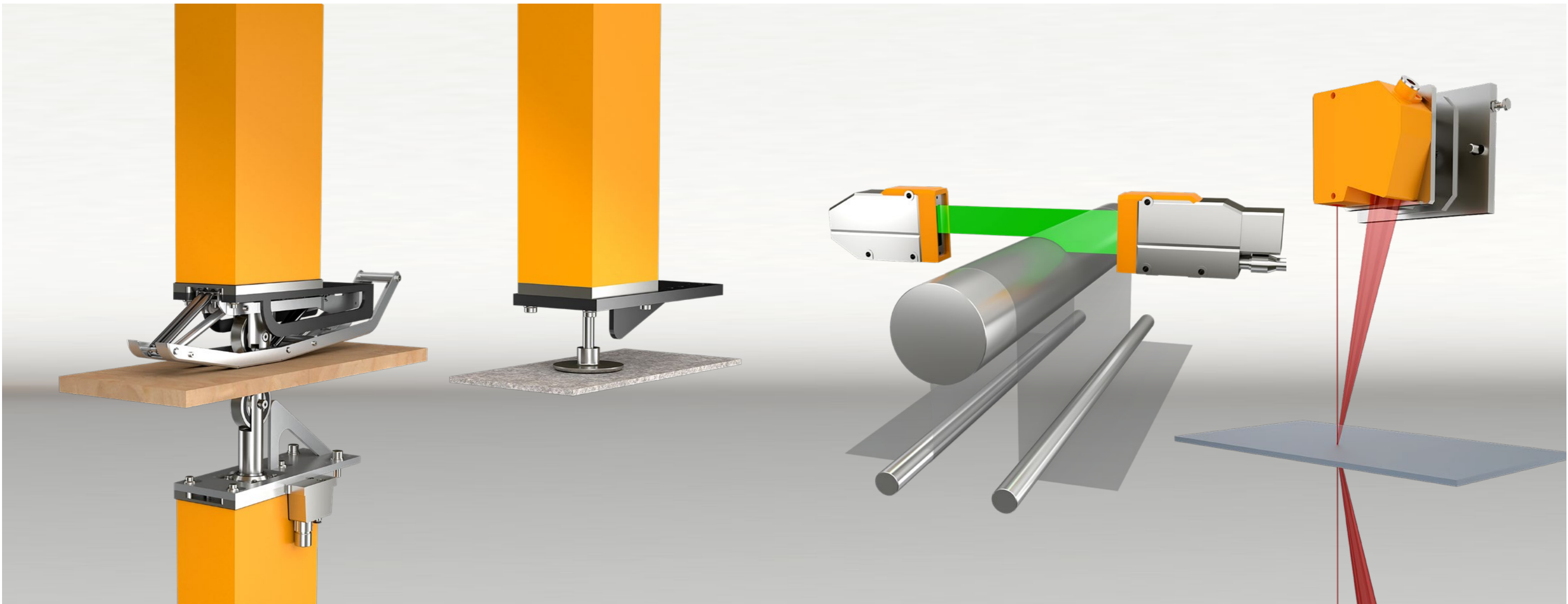

## THE APPROPRIATE MEASURING PROCESS FOR YOUR PRODUCTION

### THE MODULAR SYSTEM DESIGN MAKES INDIVIDUAL SOLUTIONS POSSIBLE

The GreCon thickness measuring systems consist of measuring sensors, O-frame, control centre and measured data computer. These basic components are selected and combined depending on the measuring job and the installation situation.

Numerous aspects have to be taken into consideration when designing the thickness measuring system suitable for your production process. The production process decides e.g. whether measuring has to take place in production direction, in a traversing or stationary way.

If the material is solid, a roller or a sensing device can be used as measuring sensor. In case of soft material, measurement must be contactless, e.g. by means of a laser. If this soft material is transparent, as for example films, an optical micrometre is used.

Furthermore, possible perturbations must be identified and compensated. Thus, it is possible that e.g. vibrations, deformations or irregularities occur in the material transport which cannot be excluded in the difference measurement process. Thermal deformations, which result in measurement deviations, are compensated by regular automatic calibrations.

06/07

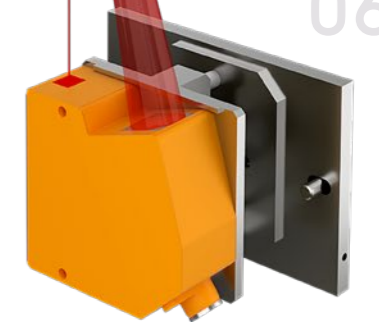



08/09

## IMPORTANT INFORMATION AT A GLANCE

### QUICK REACTION IN CASE OF DEVIATIONS OF THE MEASURED VALUES

The user interface can be adapted to the needs of the operator without any problem. The operator receives the information relevant for his respective job quickly and clearly in a numerical or graphic representation. Deviations from the regular production process are clearly signalled thanks to the user-friendly visualisation software and make a quick and effective intervention of the operator possible. Detailed reports can be created for a further analysis.

The user interfaces can be arranged according to the same principle for all Fagus GreCon measuring technology systems. The easy menu structure, which is the same for all measuring systems, enhances an intuitive and user-friendly operation and allows quick familiarisation with new systems.

Upstream or downstream process steps can be controlled by the connection of the thickness measuring system to an automatic control loop via relays or a programmable logic controller (PLC).

#### Digital interfaces

- OPC
- Ethernet
- Digital I/O

#### Analogue interfaces

- 4...20 mA
- 0...10 V

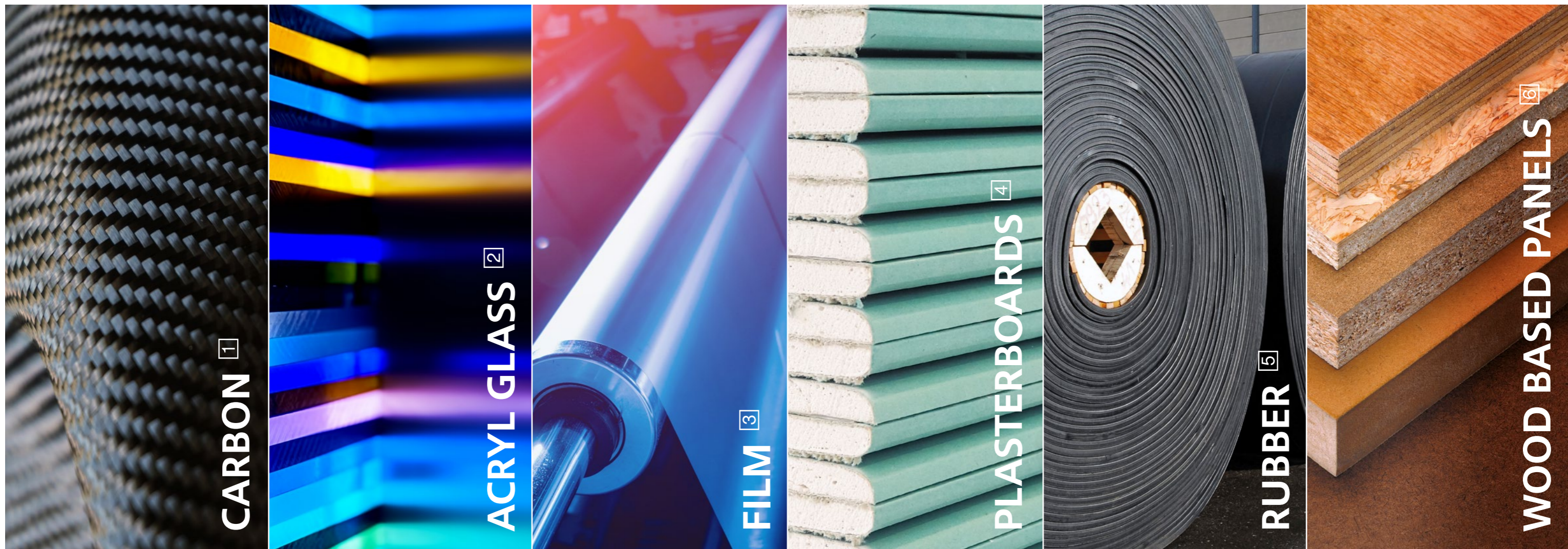

CARBON <sup>1</sup>

ACRYL GLASS <sup>2</sup>

FILM <sup>3</sup>

PLASTERBOARDS <sup>4</sup>

RUBBER <sup>5</sup>

WOOD BASED PANELS <sup>6</sup>

## APPLICATIONS

### COMPETENCE FOR EACH INDUSTRY

Different materials require different measuring methods to determine the thickness of the material. With the available measuring sensors and in connection with the modular design of the systems, we are able to take account of the different requirements.

- <sup>1</sup> High-resolution probe or roller measuring heads are often used in line with the special requirements of the carbon material. The place of use is the final quality control. Measurement takes place in production or at a test station.
- <sup>2</sup> Acryl glass is measured as piece good in the passage. The optical properties of the material exclude a laser measurement. The sensitive surfaces require contact roller measuring heads which are optimally matched to the product.

- <sup>3</sup> Thickness measurement takes place preferentially behind the ring extruder or the flat film extruder when films are produced. The measured values which are recorded by an optical micrometre with the shadowing method can be used directly for production optimisation and are fed back.
- <sup>4</sup> The continuous quality control of plasterboards and gypsum fibreboards can be carried out by laser measuring heads. Components adapted to the harsh environment provide for a reliable availability of the measuring system.
- <sup>5</sup> Thickness measuring systems with optical micrometre are used directly behind the calender and downstream to the vulcanisation system for production optimisation and quality control of the rubber production.
- <sup>6</sup> In the wood based panel industry, thickness measuring systems are used with laser or roller technology depending on the installation situation. Typical places of installation are behind the hot press or in the sanding line. Direct feedback of the measured values makes a continuous optimisation of the production possible.



COMPOSITE <sup>7</sup>

PLASTIC <sup>8</sup>

MINERAL WOOL <sup>9</sup>

NON-WOVEN FABRICS <sup>10</sup>

PVC <sup>11</sup>

FOAMS <sup>12</sup>

## APPLICATIONS

### COMPETENCE FOR EACH INDUSTRY

- <sup>7</sup> The quality assurance is of utmost importance in case of composite materials. Thickness measuring systems with laser or roller technology are used depending on the optical properties and the strength of the material. Measurement takes place in production or at a test station. Requirements from test standards as the size of supports or the pressure are observed.
- <sup>8</sup> As a panel material, the correct thickness of the plastic is typically controlled with a roller thickness measuring system in the passage. A laser is used in case of sensitive surfaces.
- <sup>9</sup> Depending on the production, stationary or traversing laser thickness measuring systems are used for mineral wool. They help to optimise this energy-intensive production process and to reduce costs.

- <sup>10</sup> The challenges which measuring sensors have to meet in case of non-woven fabrics are special. Traversing thickness measuring systems with laser measuring heads are used in the continuous production process. The principal task is the final quality control.
- <sup>11</sup> Stationary as well as traversing systems with laser, probe or roller measuring heads are used for the quality control of PVC sheet rolls.
- <sup>12</sup> The thickness measurement of foamed material is mainly used for the final quality control.

The flexibility of the material makes the use of laser measuring heads necessary. GreCon thickness measuring systems can be used flexibly. Just contact us if your application is not described here. We will find a solution.



## MAXIMUM AVAILABILITY OF YOUR THICKNESS MEASURING SYSTEM

14/15

### INDIVIDUAL SERVICE ACCORDING TO YOUR NEEDS

It is our goal to achieve the maximum availability and reliability of your GreCon system. Our worldwide service network helps to implement and maintain your GreCon systems.

Thanks to individually combinable service modules from our customer service programme, the service which you specifically need is available to you - no matter when and where you need it.

Starting from the local project planning and the assembly support via the commissioning, the inspection or the maintenance – we compile a service package tailored to your needs – and you will always have the optimal solution to avoid

standstill times and minimise malfunctions and disruptions. We provide support where you need us. Of course, also online.

### SATELLITE - SAFE, SIMPLE AND FAST

With the remote support SATELLITE, GreCon experts are available to you worldwide in case of urgent questions or a possible failure. We will help you to make your GreCon system safe, simple and quickly available again. The access to the data history makes a specific and quick analysis of the cause of failure possible.

Thanks to GreCon SATELLITE, local interventions can be better prepared and possibly even completely avoided.



## PIONEERING SPIRIT, PASSION AND INNOVATION

We are more than just a company, we are a community where pioneering spirit and passion for excellence are our driving forces. Our employees are the key to our success, and our customers are our partners on the path to outstanding solutions.



In 1911, Carl Benscheidt founded Fagus GmbH for the production of shoe lasts and punching tools. His great-grandsons Ernst and Gerd Greten integrated the companies GreCon-Anlagenbau and GreCon-Elektronik. Numerous inventions originate from this merger, including shoe lasts for the right and left foot; measuring technology to record thickness, surface characteristics or the weight by X-ray; the industrial spark extinguishing system.

Today's Fagus-GreCon Greten GmbH & Co. KG is a family business in its fifth generation. Fagus has stood for precision and fit for over 100 years and is an established partner for the international shoe industry. GreCon has been supplying sophisticated solutions for a wide range of applications in various industries in the "fire protection" and "measurement technology" sectors for 50 years. Thanks to numerous innovations and the commitment of our more than 700 employees worldwide, we have been able to establish ourselves as a leading international partner for our customers in each of these areas.

The UNESCO World Heritage Fagus Factory is a special fourth business unit as a cultural enterprise within an industrial setting. In 2011, the building complex at the Alfeld site was listed as the "UNESCO World Heritage Fagus Factory". The Fagus factory built in 1911 as the first building of the architect and founder of the Bauhaus, Walter Gropius, is considered the origin of the modern era of architecture.

### **Fagus-GreCon Greten GmbH & Co. KG**

Hannoversche Straße 58 . 31061 Alfeld . Germany

+49 5181 790 . [info@fagus-grecon.com](mailto:info@fagus-grecon.com)

[www.fagus-grecon.com](http://www.fagus-grecon.com)

### **GreCon América Latina**

R. São Bento . 1859 . Hauer Curitiba . PR . Brazil 81630-230  
+55 41 3099 7676 . [galcomercial@fagus-grecon.com](mailto:galcomercial@fagus-grecon.com)